



# GENERATOR TYPE ECO 32-2L/4

Document : **DS009A/1**

issue 009 date 13/11/2012

Electrical Characteristics										
Frequency	Hz	50				60				
Voltage (series star)	V	380	400	415	440	415	440	460	480	
Rated power class H	kVA	63	63	63	52	63	71	75,5	75,5	
	kW	50	50	50	42	50	56,8	60,4	60,4	
Rated power class F	kVA	60	60	60	47	58	68	72	72	
	kW	48	48	48	38	46	54	57,6	57,6	
Regulation with	DSR	±1 % with any power factor and speed variations between -5% +30%								
Insulation class		H								
Execution		Brushless								
Stator winding		12 ends								
Rotor		with damping cage								
Efficiencies class H	4/4	%	90,1	90,2	89,9	89,4	92,1	92,6	92,7	92,8
(see graph. for details)	3/4	%	90,5	90,8	90,7	90,4	92,7	92,9	93,1	93,3
	2/4	%	89,4	89,5	89,5	89,5	90,8	90,9	91	91,1
	1/4	%	86,2	86	85,8	85,5	87	87	87	87
Reactances (f. l.cl. F)	Xd	%	314,1	283,5	263,4	193,4	316,5	317,3	308,7	284
	Xd'	%	14,85	13,4	12,45	9,14	14,96	15,00	14,59	13,4
	Xd''	%	7,91	7,14	6,63	4,87	7,97	7,99	7,77	7,14
	Xq	%	123,0	111	103,1	75,7	123,9	124,2	120,9	111
	Xq'	%	123,0	111	103,1	75,7	123,9	124,2	120,9	111
	Xq''	%	38,3	34,6	32,1	23,6	41,5	36,8	34,6	34,6
	X <sub>2</sub>	%	25,93	23,4	21,74	15,96	26,12	26,19	25,48	23,4
	X <sub>0</sub>	%	3,49	3,15	2,93	2,15	3,52	3,53	3,43	3,15
Short Circuit Ratio	Kcc		0,47	0,59	0,69	1,29	0,34	0,39	0,47	0,59
Time Constants	Td'	sec.	0,062							
	Td''	sec.	0,014							
	Tdo'	sec.	1,20							
	Tα	sec.	0,028							
Short Circuit Current Capacity		%	>300				>350			
Excitation at no load	Amp.		0,5	0,6	0,7	1	0,3	0,4	0,45	0,6
Excitation at full load	Amp.		2	2	2,5	2,9	1,7	1,8	1,9	2,1
Overload (long-term)	%	1 hour in a 6 hours period 110% rated load								
Overload per 20 sec.	%	300								
Stator Winding Resistance (20°C)	Ω	0,041								
Rotor Winding Resistance (20°C)	Ω	2,861								
Exciter Resistance (20 °C)	Ω	Rotor : 0,442				Stator : 11,35				
Heat dissipation at f.l.cl.H	W	5538	5476	5662	4932	4323	4539	4756	4686	
Telephone Interference		THF < 2%				TIF < 45				
Radio interference		EN61000-6-3, EN61000-6-1. For others standards apply to factory								
Waveform Distors.(THD) at f. load	LL/LN %	3,8 / 3,6								
Waveform Distors.(THD) at no load	LL/LN %	3 / 2,9								
<b>Mechanical characteristics</b>										
Protection		IP 21 (other protection on request)								
DE bearing		6312-2RS								
NDE bearing		6309-2RS								
Weight of wound stator assembly	kg	95								
Weight of wound rotor assembly	kg	64,5								
Weight of complete generator	kg	282								
Maximum overspeed	rpm	2250								
Unbalanced magnetic pull at f.l.cl.F	kN/mm	4,7								
Cooling air requirement	m <sup>3</sup> /min	11,8				14,5				
Inertia Constant (H)	sec.	0,098				0,118				
Noise level at 1m/7m	dB(A)	75 / 60				79 / 64				

All technical data are to be considered as a reference and they can be modified without any notice.

This document is a propriety of Mecc Alte S.p.a..All rights reserved.

**50 Hz**

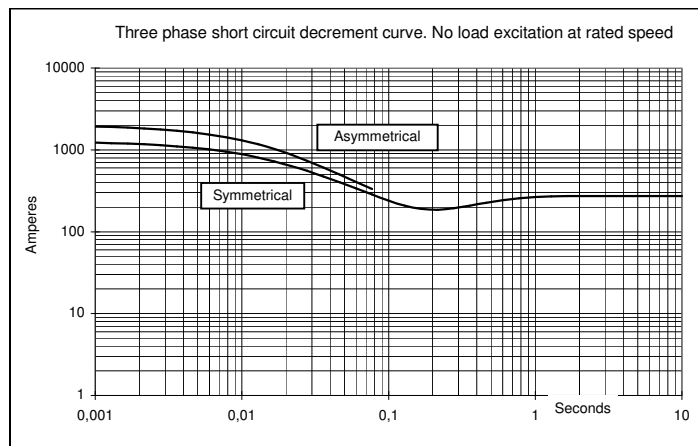
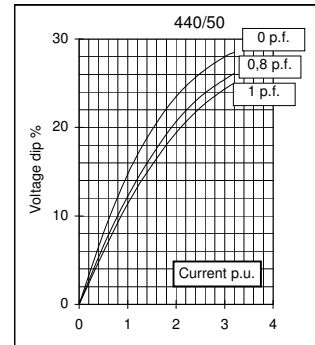
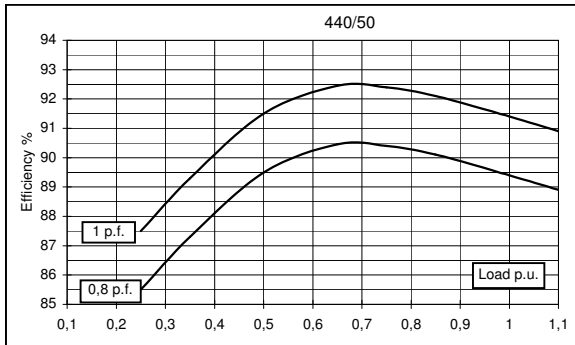
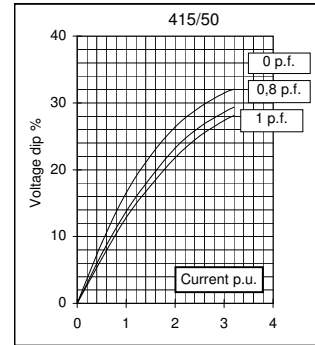
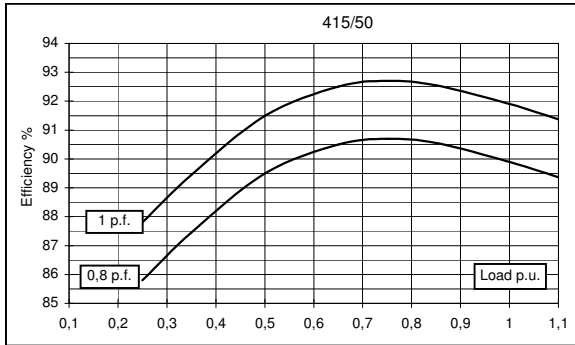
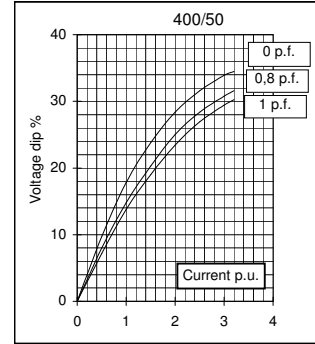
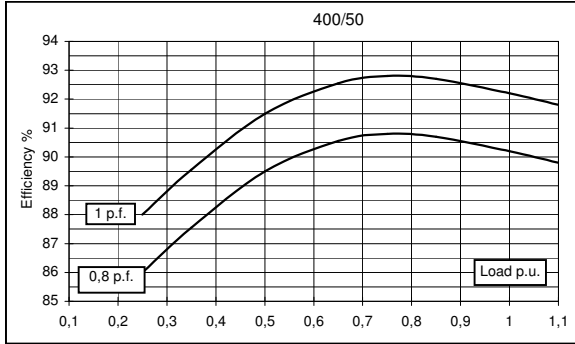
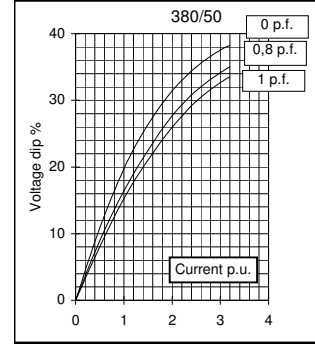
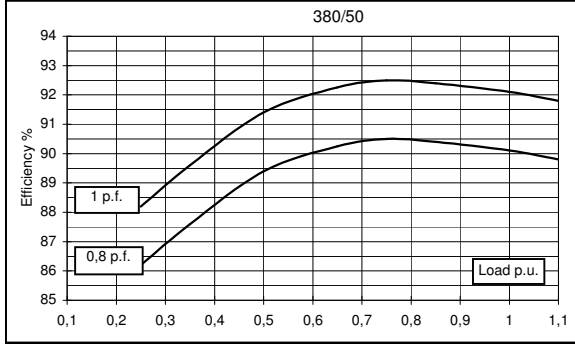

**60 Hz**

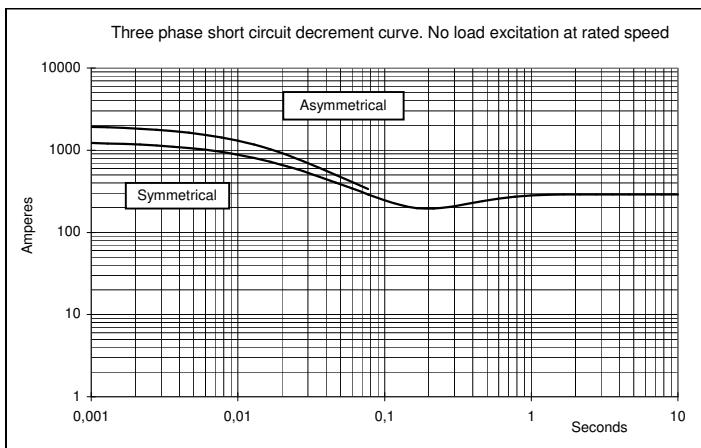
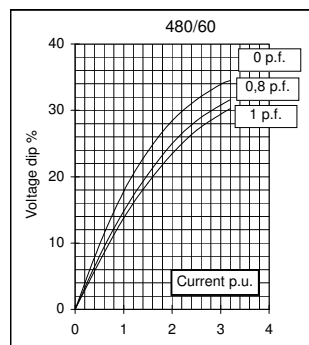
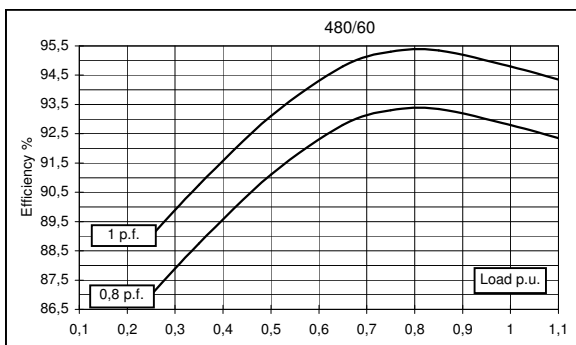
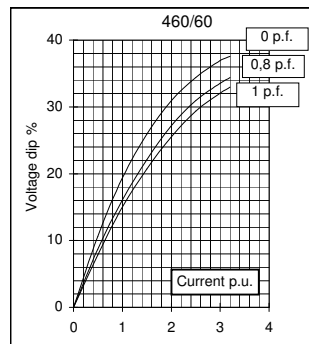
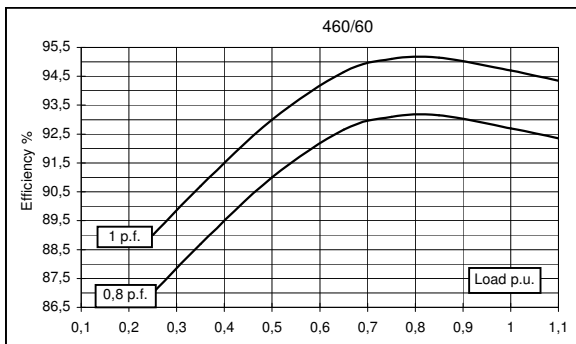
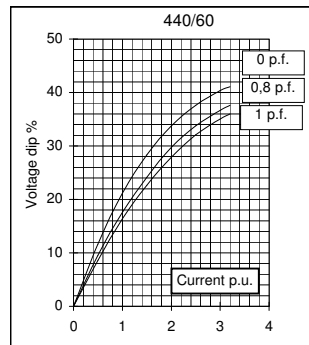
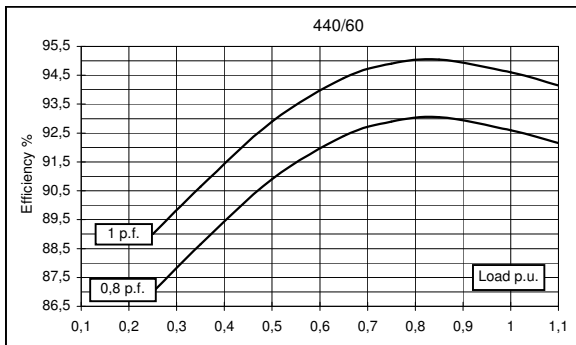
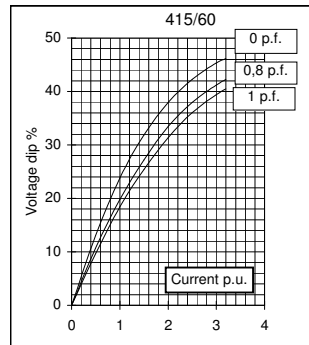
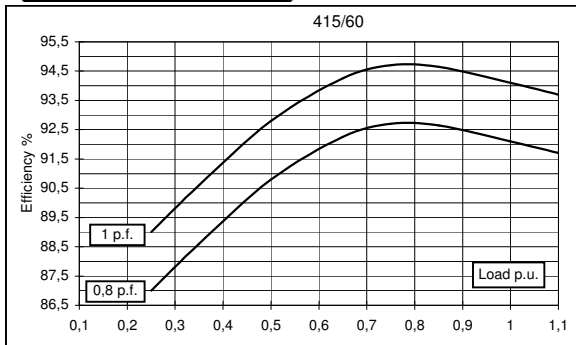



### SINGLE BEARING MOMENTS OF INERTIA

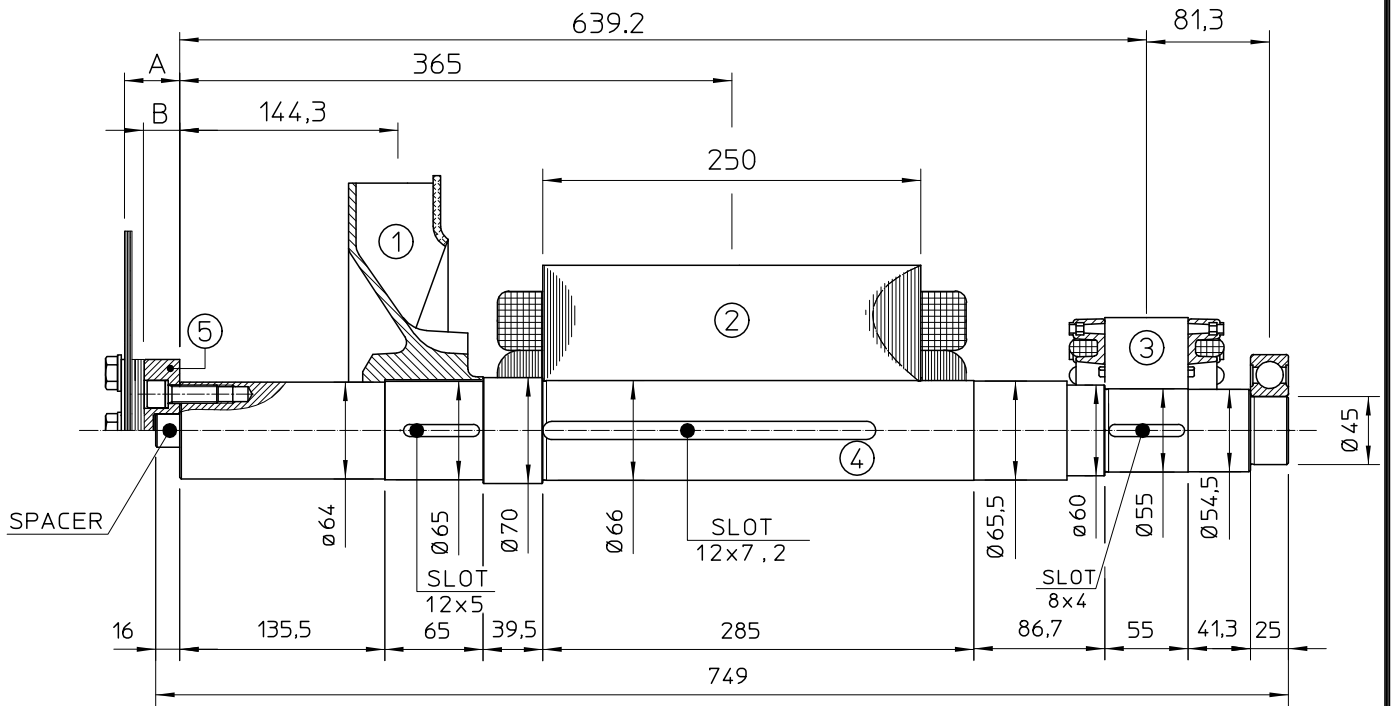

POS.	COMPONENT	WEIGHT (kg)	J (kgm <sup>2</sup> )
1	FAN	2.3	0.0224
2	MAIN ROTOR	64.5	0.4579
3	EX. ROTOR	7	0.016
4	SHAFT	17.6	0.0090
TOTAL		91.4	0.5053

SAE N°	5		SHAFTS COUPLING FLEX PLATE	
	A	B	WEIGHT kg	J kgm <sup>2</sup>
6.5	5	2.5	1.74	0.0084
7.5	5	2.5	2.1	0.013
8	36.6	28.1	3.9	0.02
10	28.6	21.6	4.47	0.038
11.5	15	11.5	4.51	0.059

### SINGLE BEARING DIMENSIONS

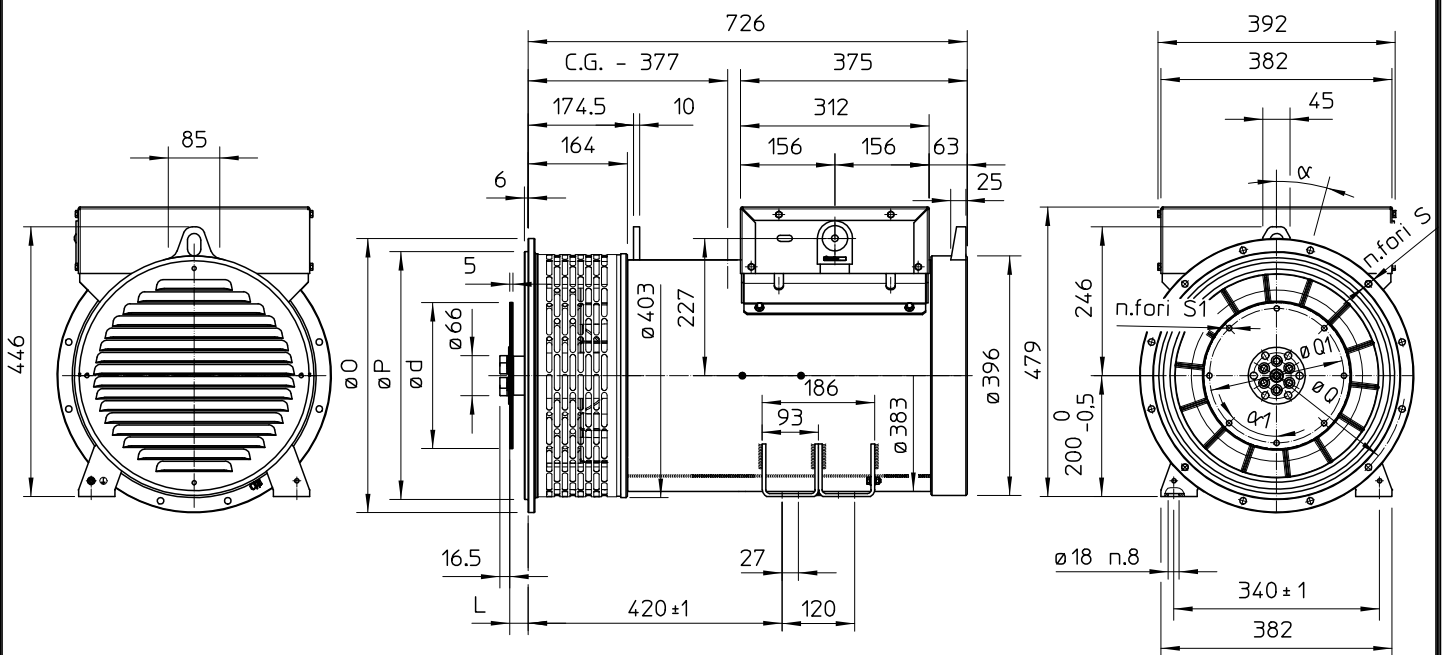

SAE N.	FLANGIA / FLANGE BRIDE / FLANSCH					
	O	P	Q	S	N. FORI HOLES N°	α
5	356	314.3	333.4	11	8	45
4	403	362	381	11	12	30
3	451	409.6	428.6	11	12	30
2	490	447.7	466.7	11	12	30
1	552	511.2	530.2	11	12	30

SAE N.	GIUNTI A DISCHI / DISC COUPLING DISCQUE DE MONOPALIER / SCHEIBENKUPPLUNG						
	d	L	Q1	S1	N. FORI HOLES N°	α1	
6 1/2	215.9	30.2	200	9	6	60	
7 1/2	241.3	30.2	222.25	9	8	45	
8	263.52	62	244.47	11	6	60	
10	314.32	53.8	295.27	11	8	45	
11 1/2	352.42	39.6	333.37	11	8	45	

C.G.= GRAVITY CENTER