



GENERATOR TYPE ECP 34-1L/4 A

Document : DS274A/1

issue 002 date 27/01/2014

Electrical Characteristics										
Frequency	Hz	50				60				
Voltage (series star)	V	380	400	415	440	415	440	460	480	
Rated power class H	kVA	135	135	135	114	140	150	162	162	
	kW	108	108	108	91	112	120	130	130	
Rated power class F	kVA	121	121	121	103	125	135	146	146	
	kW	97	97	97	82	100	108	117	117	
Regulation with DSR		±1% with any power factor and speed variations between -5% +30%								
Insulation class		H								
Execution		Brushless								
Stator winding		12 ends								
Rotor		with damping cage								
Efficiencies class H	4/4	%	92,8	92,9	92,6	92,4	94	94,5	94,7	94,8
(see graph. for details)	3/4	%	93,1	93,4	93,2	93	94,5	95	95,2	95,3
	2/4	%	91,6	91,7	91,7	91,6	93,1	93,3	93,5	93,6
	1/4	%	88,2	88,2	88,1	88	89,3	89,4	89,5	89,3
Reactances (f. l.cl. F)	Xd	%	245	222	202	161	257	250	241	222
	Xd'	%	16,8	15,4	14,4	11,5	19,5	18,0	16,8	15,4
	Xd''	%	8,1	7,6	6,9	5,4	9,7	8,9	8,1	7,6
	Xq	%	148	136	125	112	162	154	148	136
	Xq'	%	148	136	125	112	162	154	148	136
	Xq''	%	31,2	28,4	27,1	25,2	35,4	33	31,2	28,4
	X ₂	%	18,9	17,2	16,6	15,4	22,1	20,7	18,9	17,2
	X ₀	%	3,1	2,7	2,9	2,2	3,6	3,4	3,1	2,7
Short Circuit Ratio	Kcc		0,39	0,45	0,60	0,90	0,30	0,35	0,39	0,45
Time Constants	Td'	sec.	0,039							
	Td''	sec.	0,0085							
	Tdo'	sec.	1,85							
	Tα	sec.	0,0168							
Short Circuit Current Capacity		%	>300				>350			
Excitation at no load	Amp.		0,5	0,6	0,67	0,8	0,3	0,35	0,4	0,5
Excitation at full load	Amp.		2,1	2,1	2,2	2,4	2,3	2,1	2	2
Overload (long-term)		%	1 hour in a 6 hours period 110% rated load							
Overload per 20 sec.		%	300							
Stator Winding Resistance (20°C)	Ω		0,016							
Rotor Winding Resistance (20°C)	Ω		4,142							
Exciter Resistance (20 °C)	Ω		Rotor : 0,410				Stator : 15,28			
Heat dissipation at f.l.cl.H	W		8379	8254	8631	7501	7149	6984	7253	7109
Telephone Interference			THF < 2%				TIF < 40			
Radio interference			EN61000-6-3, EN61000-6-2. For others standards apply to factory							
Waveform Distors.(THD) at f. load	LL/LN %		1,7 / 1,9							
Waveform Distors.(THD) at no load	LL/LN %		2,3 / 2,5							
Mechanical characteristics										
Protection			IP 21 (other protection on request)							
DE bearing			6314.2RS							
NDE bearing			6311.2RS							
Weight of wound stator assembly	kg		152							
Weight of wound rotor assembly	kg		101,3							
Weight of complete generator	kg		467							
Maximun overspeed	rpm		2250							
Unbalanced magnetic pull at f.l.cl.F	kN/mm		5,7							
Cooling air requirement	m ³ /min		19,3				23			
Inertia Constant (H)	sec.		0,098				0,118			
Noise level at 1m/7m	dB(A)		79 / 65				83 / 69			

All technical data are to be considered as a reference and they can be modified without any notice.

This document is a propriety of Mecc Alte S.p.a..All rights reserved.

50 Hz

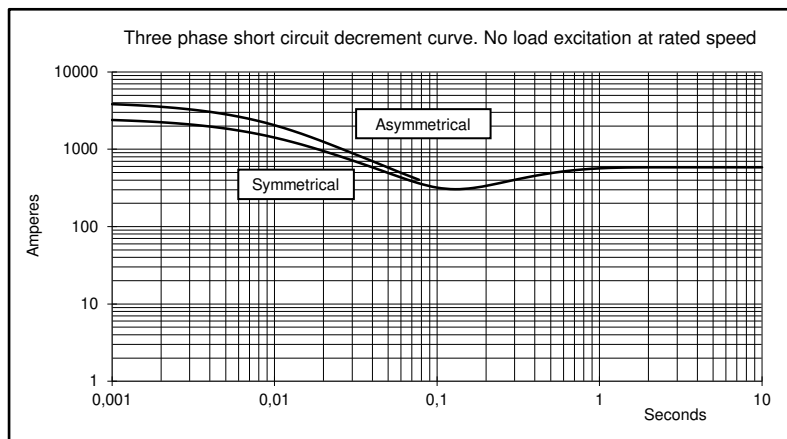
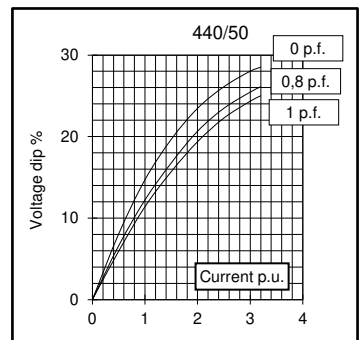
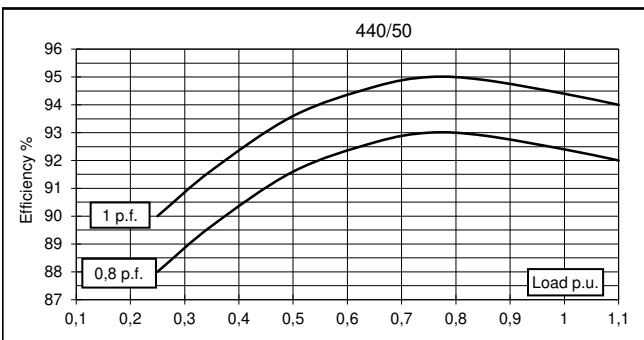
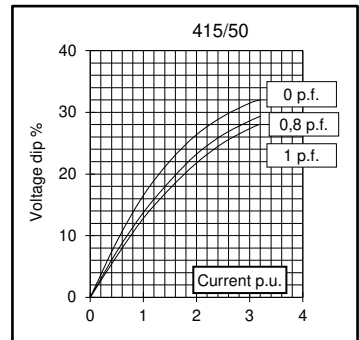
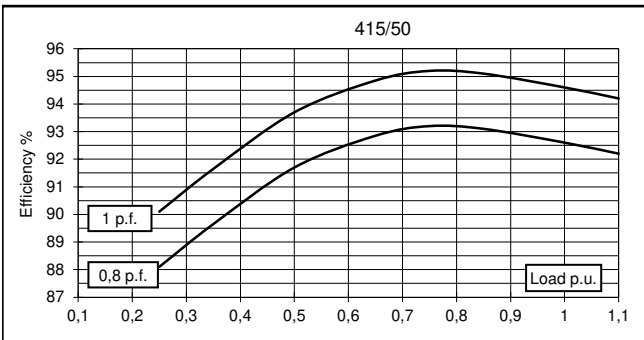
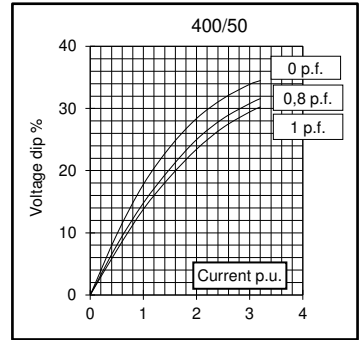
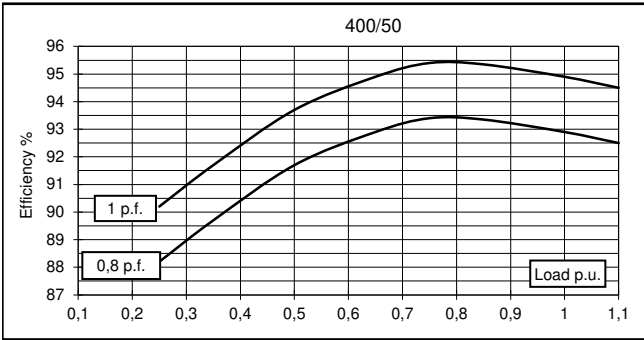
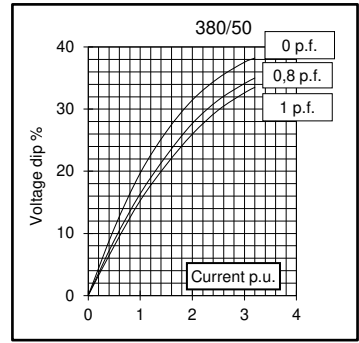
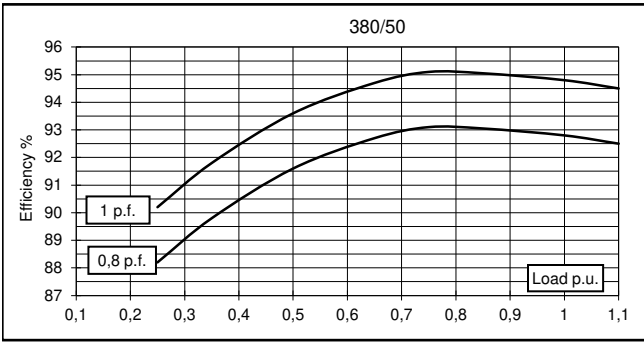

60 Hz

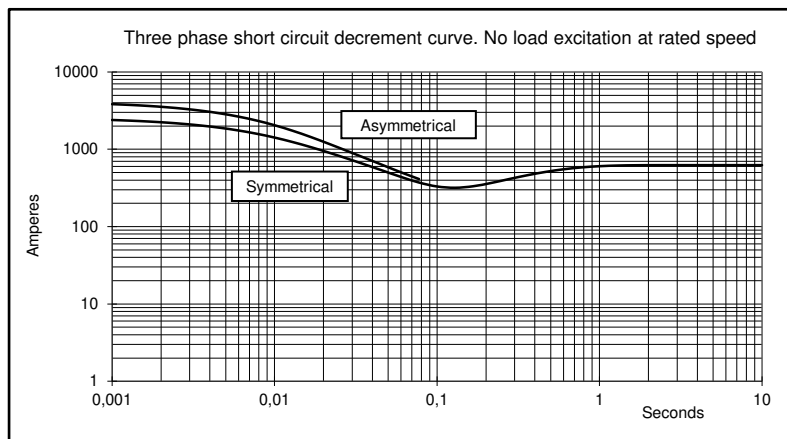
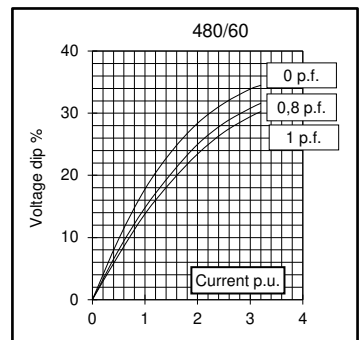
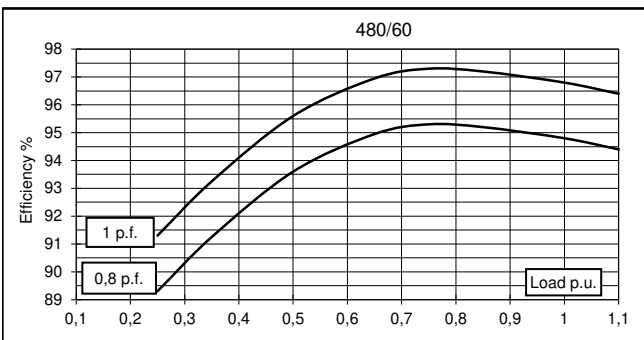
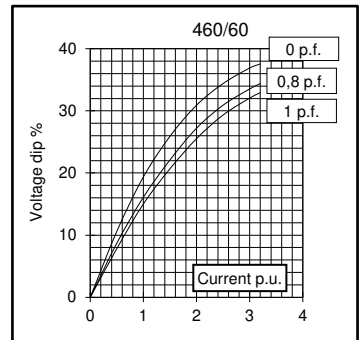
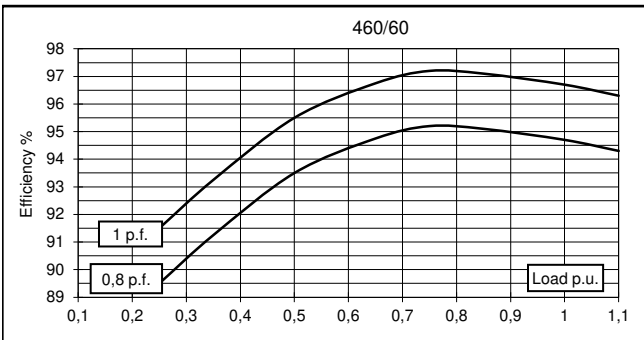
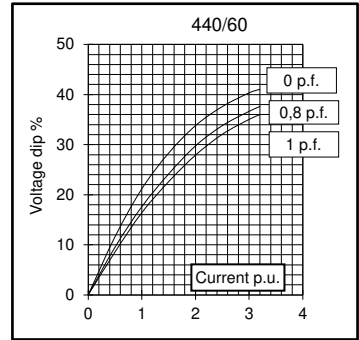
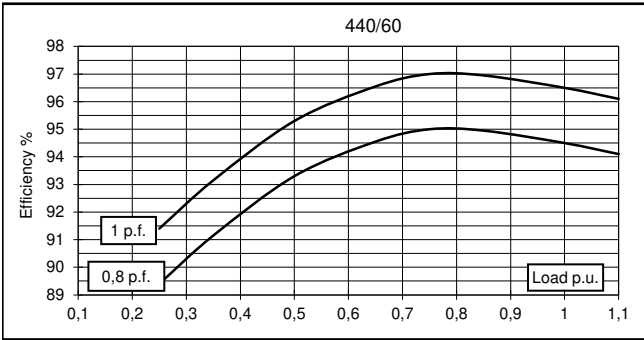
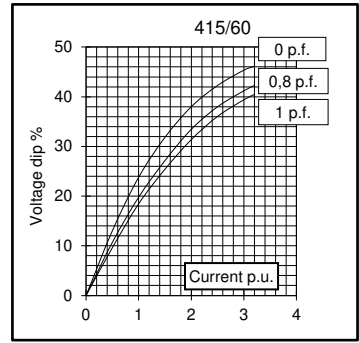
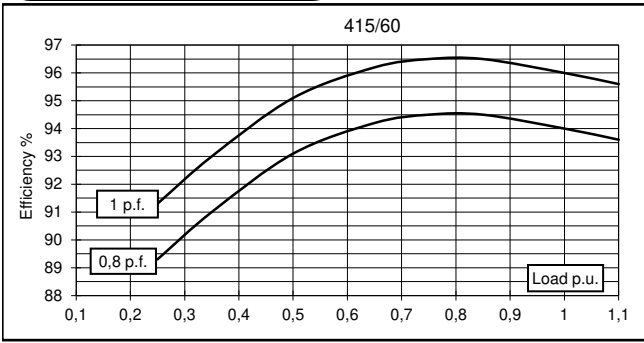

TWO BEARING MOMENTS OF INERTIA

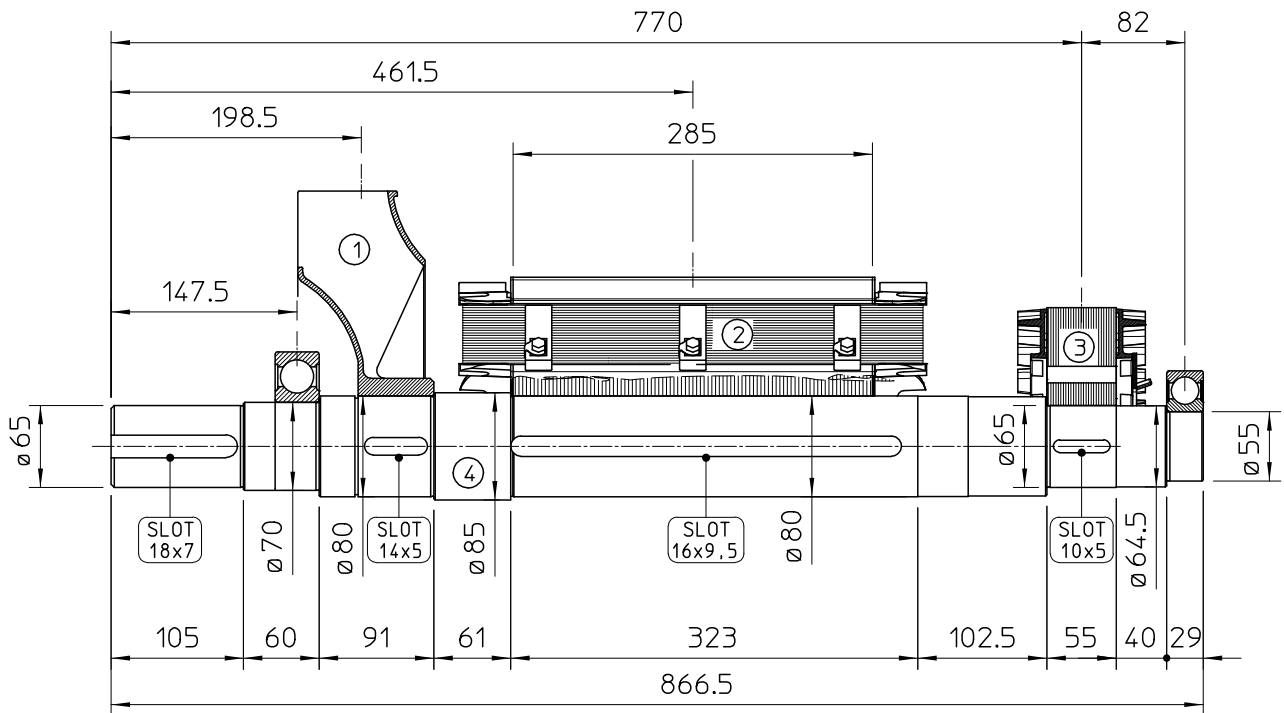

POS.	COMPONENT	WEIGHT (kg)	J (kgm ²)
1	FAN	3.6	0.0451
2	MAIN ROTOR	101.3	0.9153
3	EX. ROTOR	14.5	0.0874
4	SHAFT	29.6	0.0218
TOTAL		149	1.0696

TWO BEARING DIMENSIONS

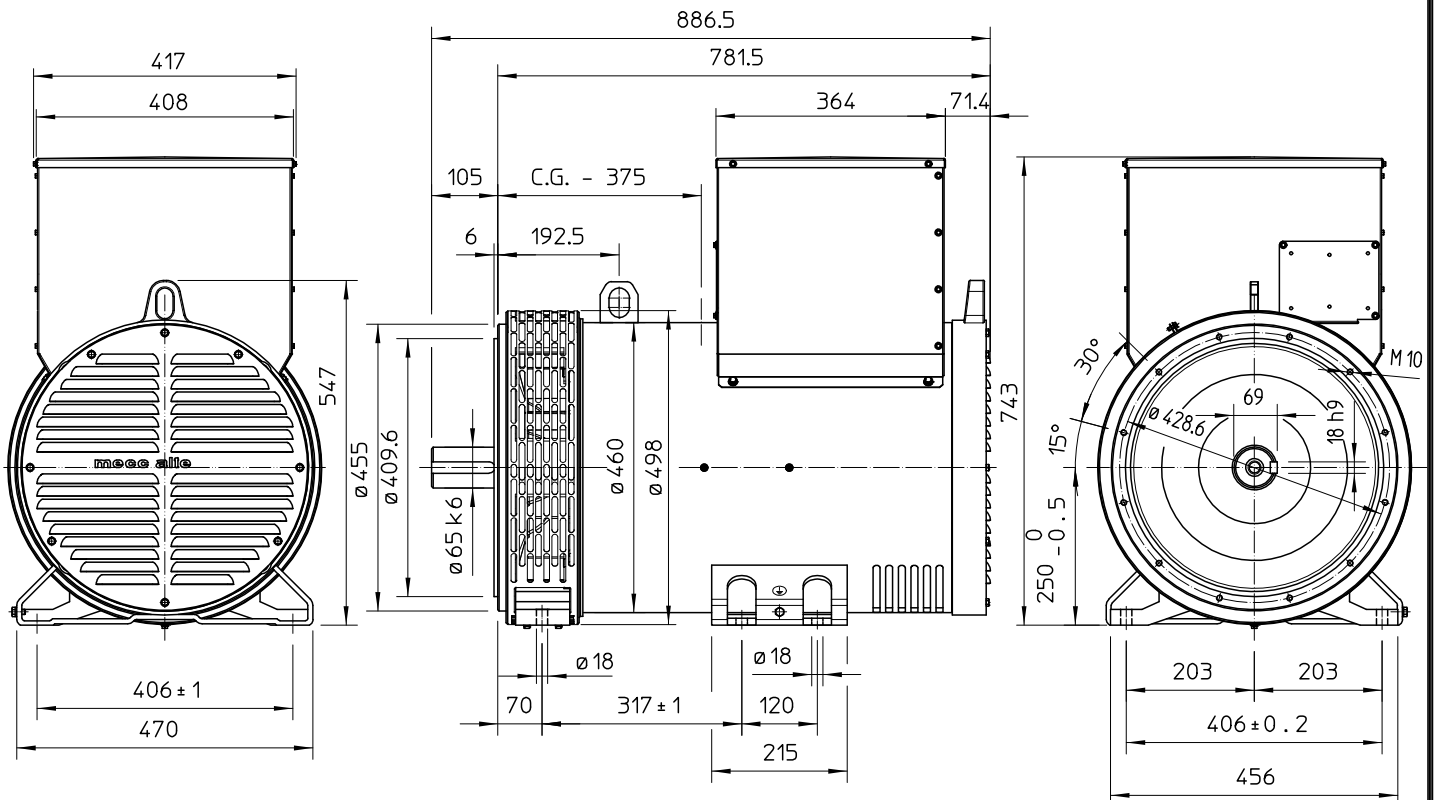

C.G.= GRAVITY CENTER

SINGLE BEARING MOMENTS OF INERTIA

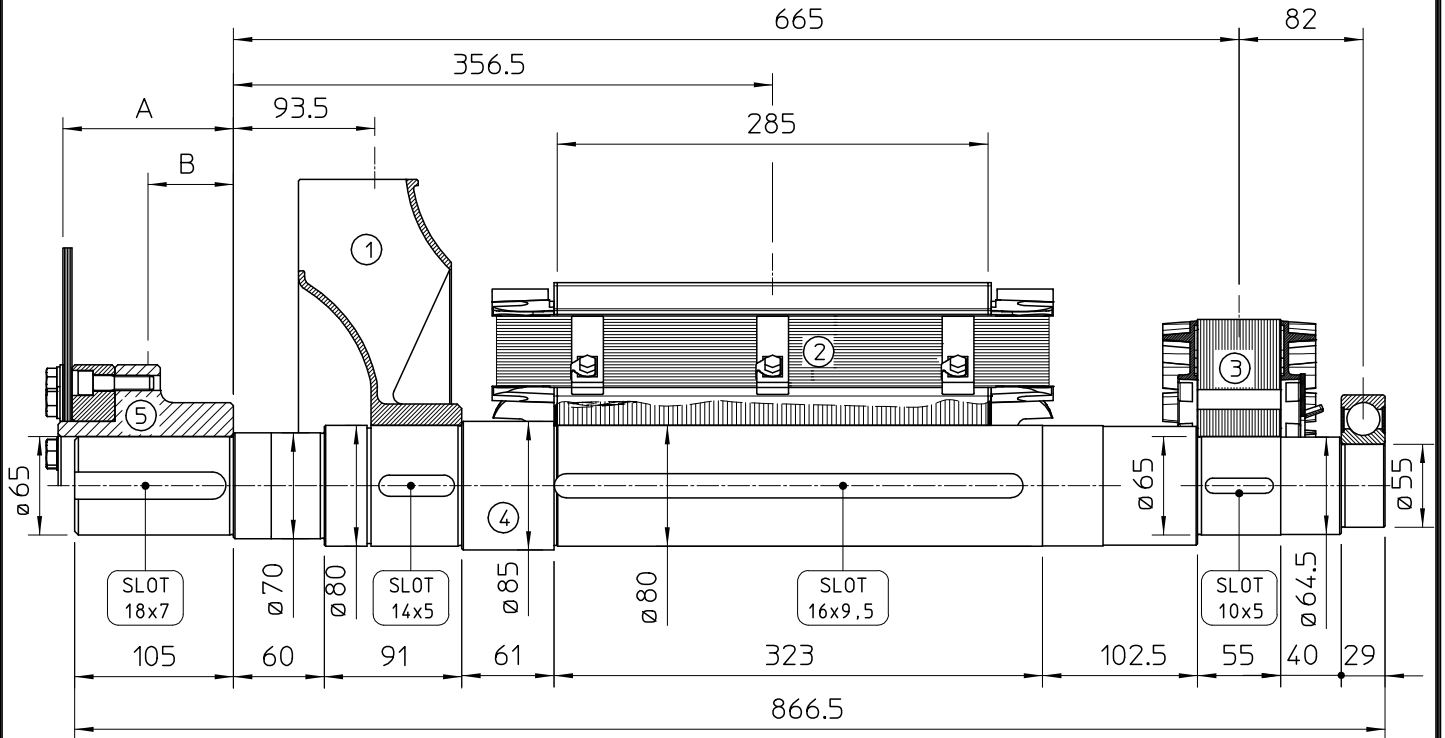

POS.	COMPONENT	WEIGHT (kg)	J (kgm ²)
1	FAN	3.6	0.0451
2	MAIN ROTOR	101.3	0.9153
3	EX. ROTOR	14.5	0.0874
4	SHAFT	29.6	0.0218
TOTAL		148.8	1.0696

SAE N°	5		SHAFTS COUPLING FLEX PLATE	
	A	B	WEIGHT kg	J kgm ²
10	112.8	35.6	13.5	0.0770
11 1/2	98.6	71.5	12.4	0.0956
14	84.4	68.6	14.8	0.2360

SINGLE BEARING DIMENSIONS

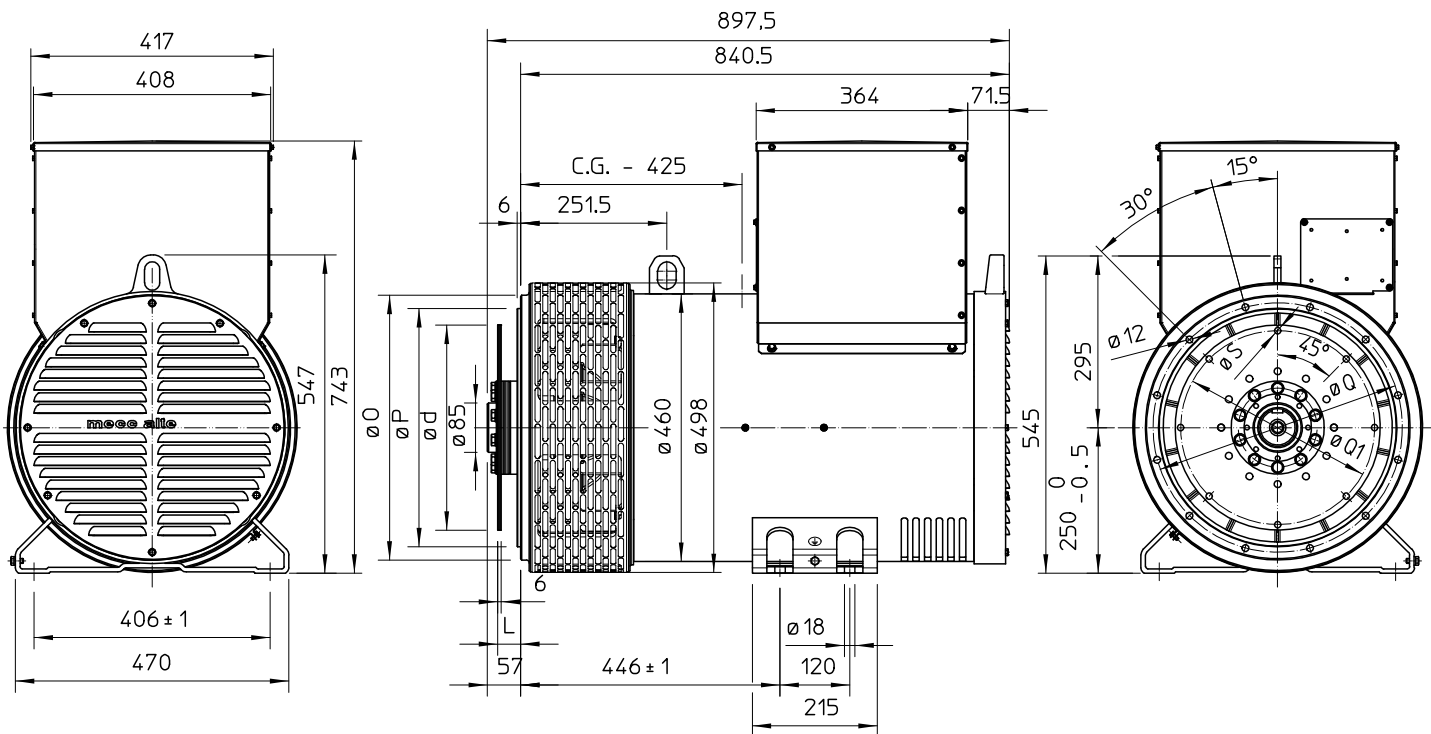

SAE N.	FLANGIA / FLANGE BRIDE / FLANSCH		
	O	P	Q
3	451	409.6	428.6
2	489	447.7	466.7
1	552	511.2	530.2

SAE N.	GIUNTI A DISCHI / DISC COUPLING DISCQUE DE MONOPALIER / SCHEIBENKUPPLUNG			
	L	d	Q1	S
10	53.8	314.32	295.27	11
11 1/2	39.6	352.42	333.37	11
14	25.4	466.72	438.15	14

C.G.= GRAVITY CENTER